

REED SWITCH

ORD229

High Breakdown Voltage

■ GENERAL DESCRIPTION

The ORD229 is a single-contact reed switch designed for high breakdown voltage of 600 VDC and high power of AC 70 VA and DC 50 W. The contacts are sealed within the glass tube with inert gas to maintain contact reliability.

■ FEATURES

- (1) Reed contacts are hermetically sealed within a glass tube with inert gas and do not receive any influence from the external atmospheric environment.
- (2) Quick response
- (3) The structure comprises an operating system and electrical circuits coaxially. Reed switches are suited to applications in radio frequency.
- (4) Reed switches are compact and light weight.
- (5) Superior corrosion resistance and wear resistance of the contacts assures stable switching operation and long life.
- (6) With a permanent magnet installed, reed switches economically and easily become proximity switches.

■ EXTERNAL DIMENSIONS (Unit: mm)

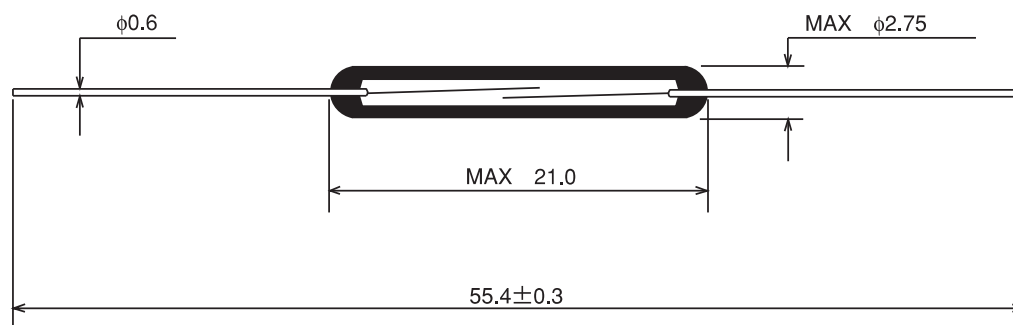

■ APPLICATIONS

- Automotive electronic devices
- Control equipment
- Communication equipment
- Measurement equipment
- Household appliances

■ ELECTRICAL CHARACTERISTICS

Parameter	Rated value	Unit
Pull-in Value (PI)	20~60	AT
Drop-out Value (DO)	6min	AT
Contact resistance (CR)	100	mΩ
Breakdown voltage	600 min (PI ≥ 35)	VDC
	500 min (PI 20 to 35)	VDC
Insulation resistance	10 ¹⁰ min	Ω
Electrostatic capacitance	0.5max	pF
Contact rating	50	W
	70	VA
Maximum switching voltage	300AC	V
	350DC	V
Maximum switching current	DC0.7/AC0.5	A
Maximum carry current	2.5	A

3

(1) Drop-out Value vs. Pull-in Value

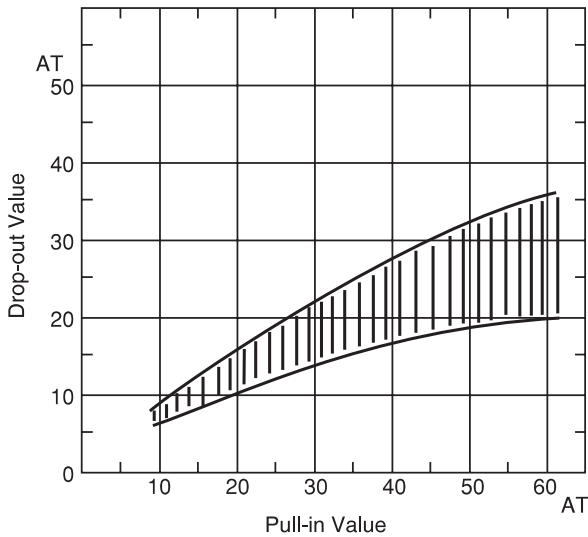

(2) Contact resistance

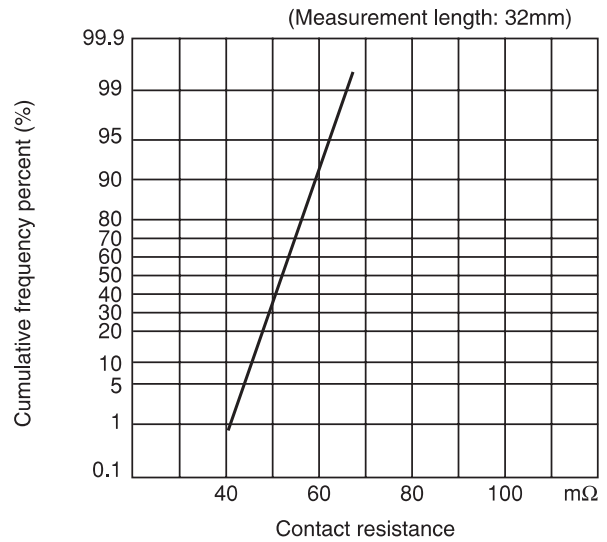

(3) Breakdown voltage

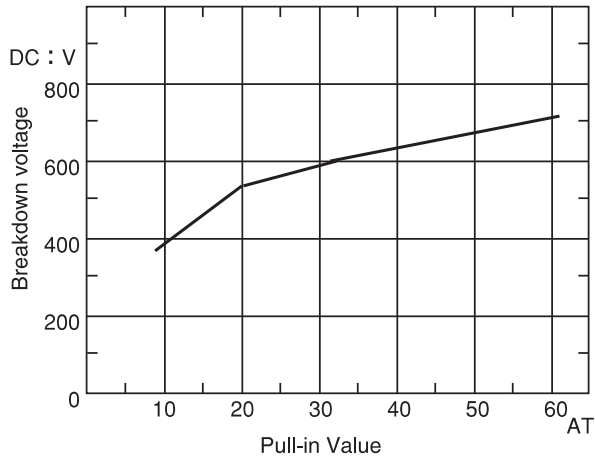

(4) Insulation resistance

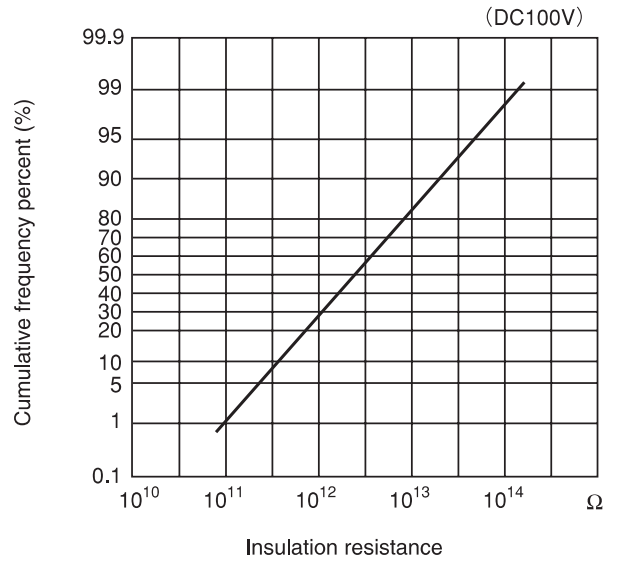

(5) Electrostatic capacitance

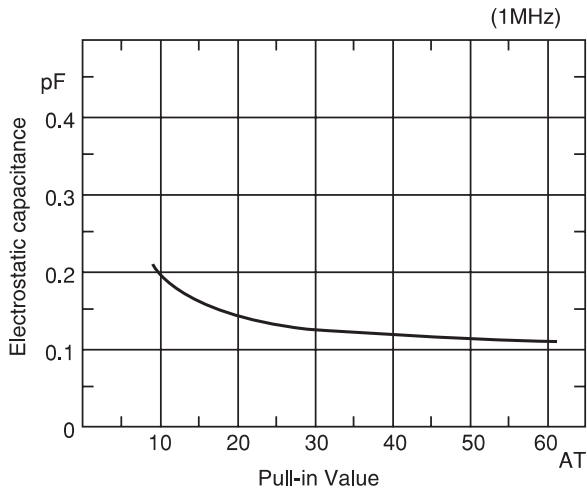

■ OPERATING CHARACTERISTICS

Parameter	Rated value	Unit
Operate time	0.6max	ms
Bounce time	0.5max	ms
Release time	0.05max	ms
Resonant frequency	2500±250	Hz
Maximum operating frequency	500	Hz

(1) Operate time

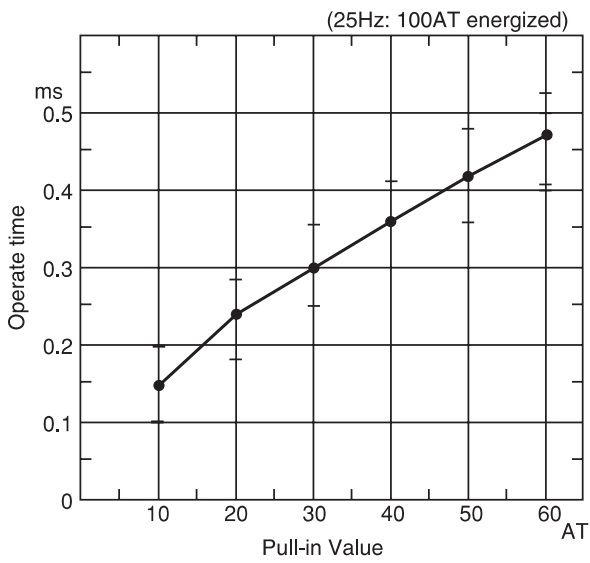

(2) Bounce time

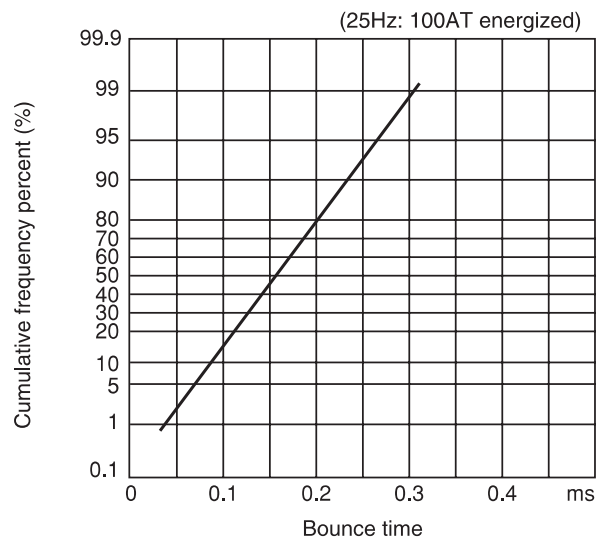

(3) Release time

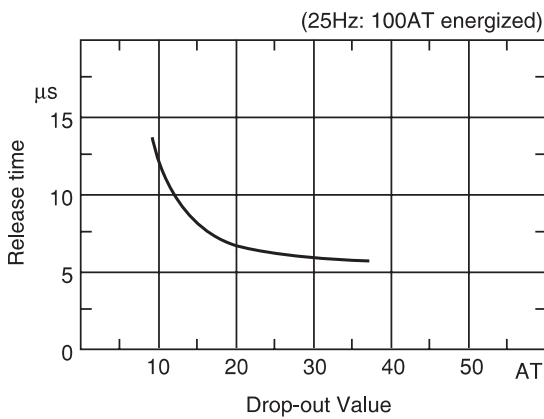

(4) Resonant frequency

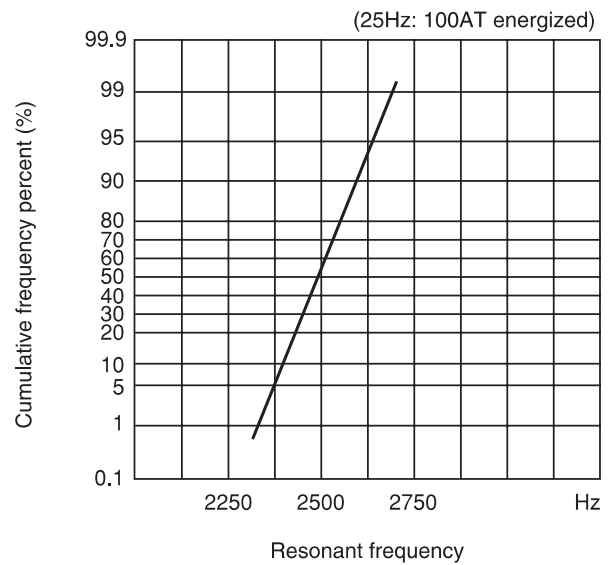

3

MECHANICAL CHARACTERISTICS

(1) Lead tensile test (static load)

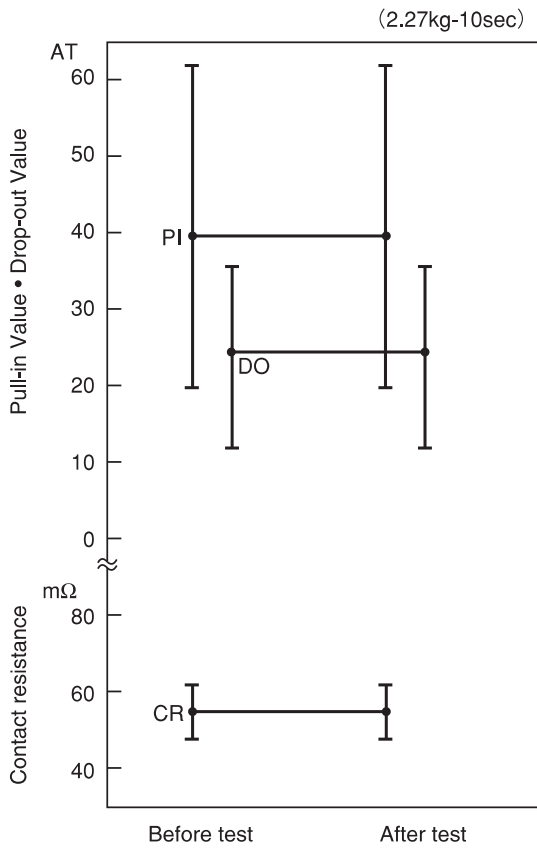

(2) Lead tensile strength

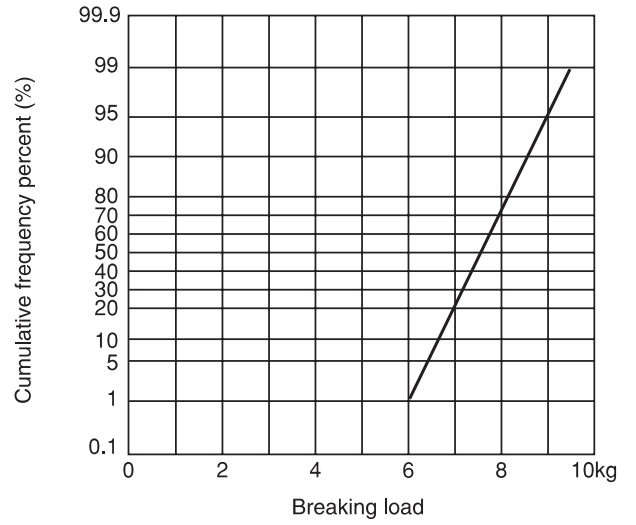

3

ENVIRONMENTAL CHARACTERISTICS

(1) Temperature characteristics

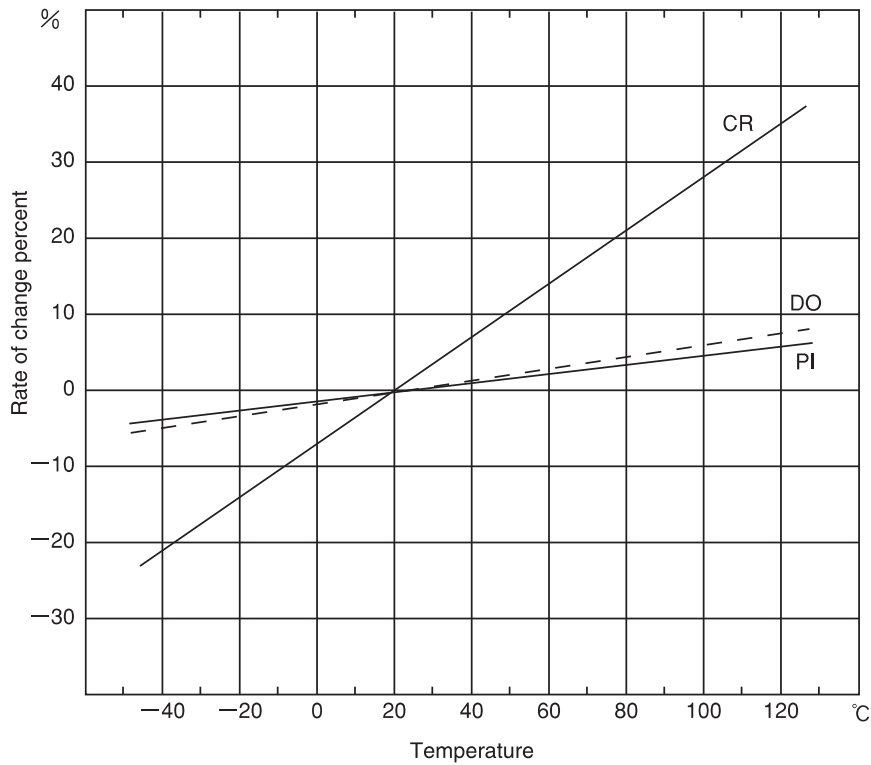

(2) Temperature cycle

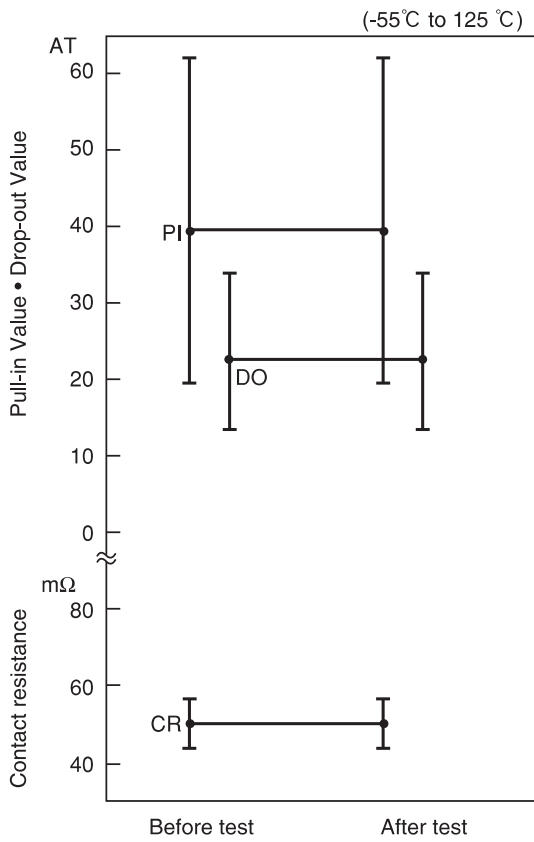

(3) Temperature and humidity cycle

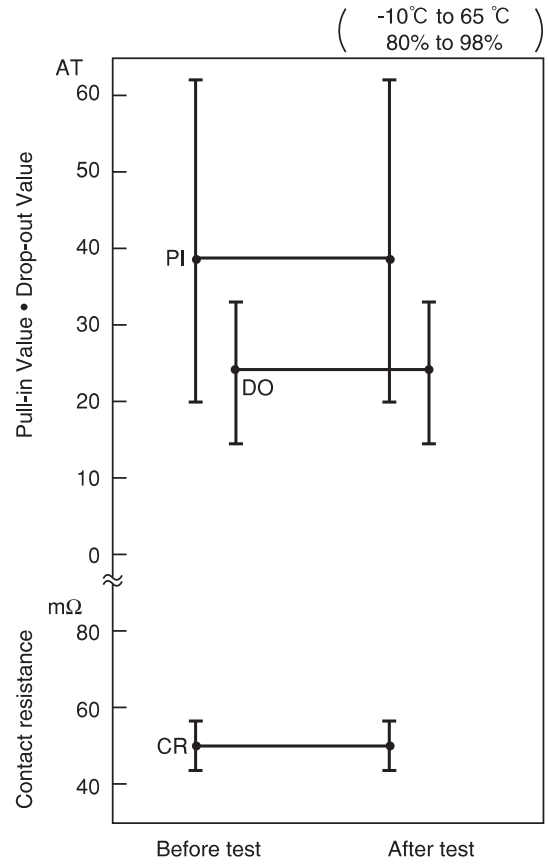

(4) High temperature storage test

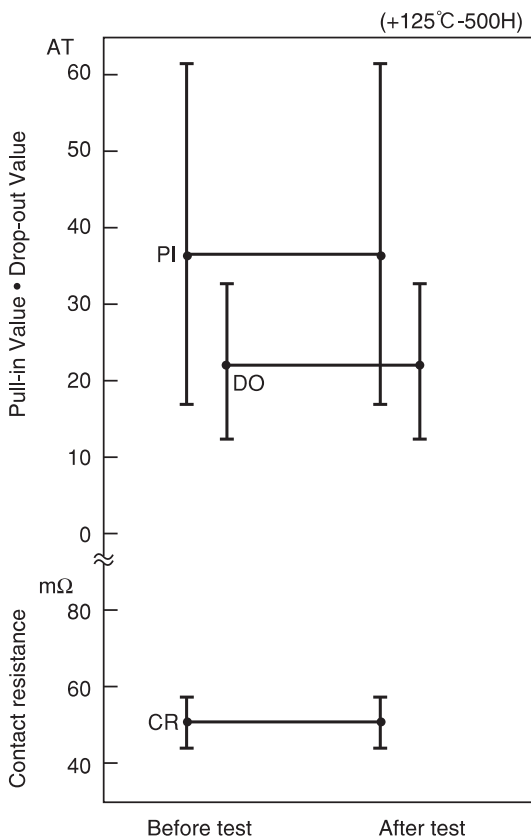

(5) Low temperature storage test

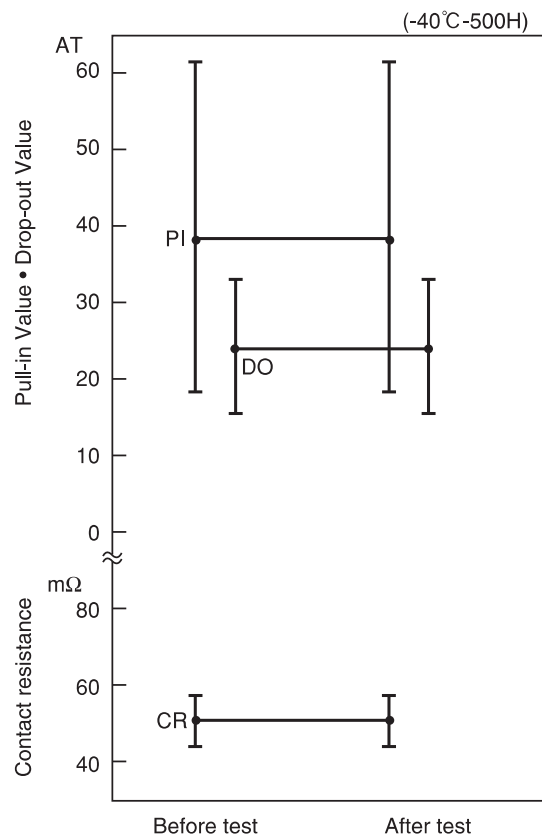

(6) Shock test

1) Electrical characteristics

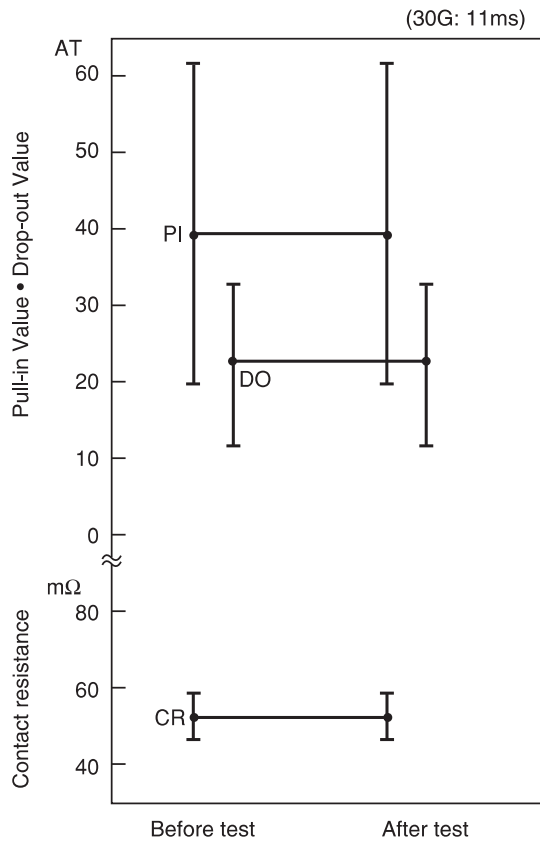

2) Misoperation area

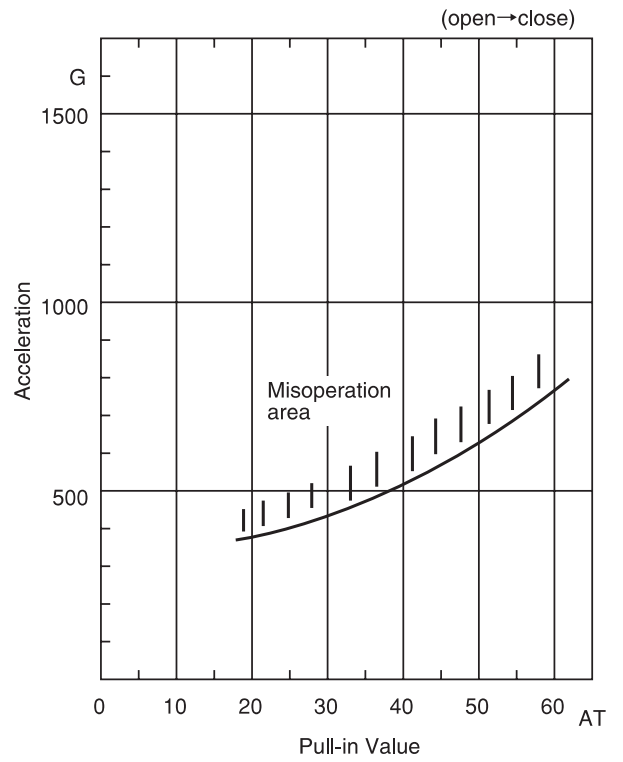

(7) Vibration test

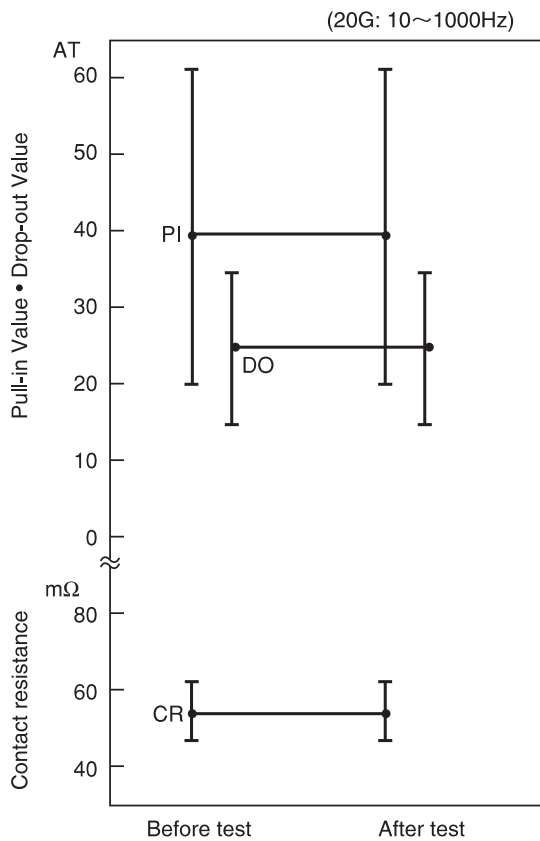

■ LIFE EXPECTANCY DATA: ORD229

Load conditions
 Voltage: 200VAC
 Current: 200mA, 250mA
 Load: Resistive load

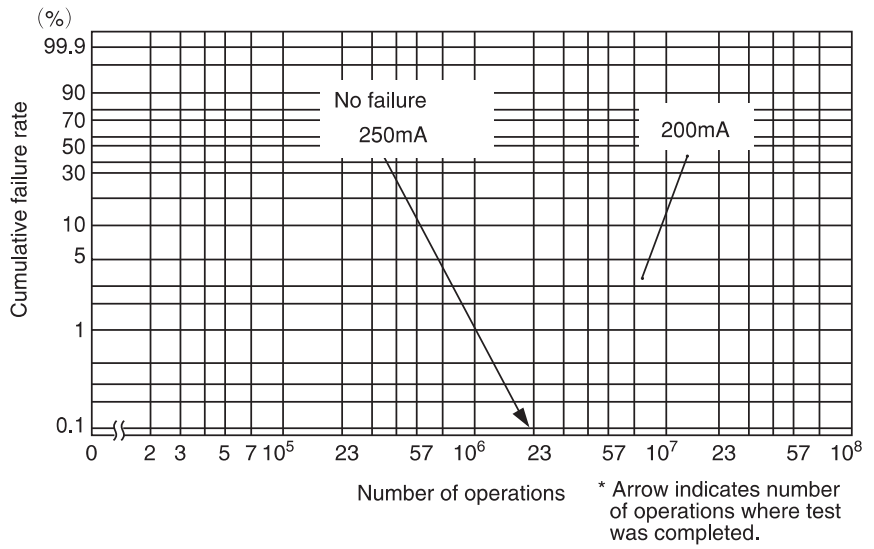

Load conditions
 Voltage: 350VDC, 270VDC
 Current: 1mA, 270µA
 Load: Resistive load

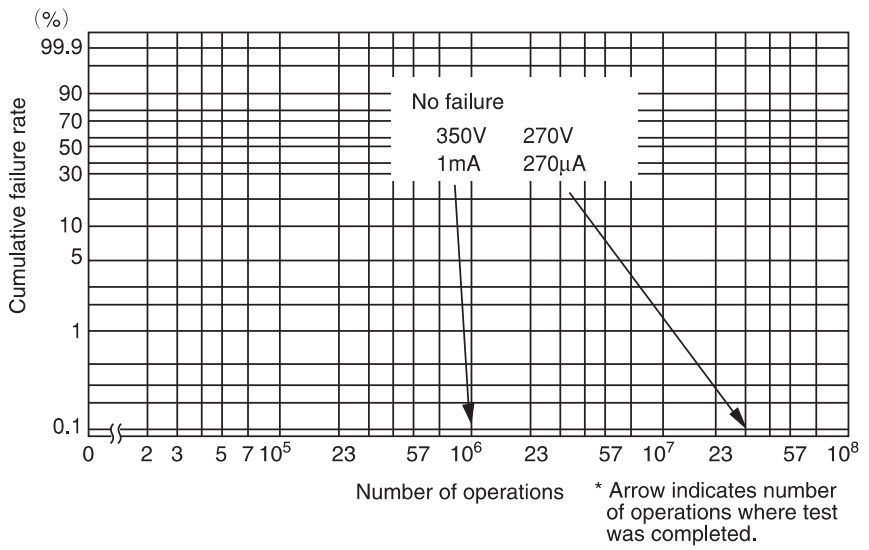

Load conditions
 Voltage: 100VDC, 50VDC
 Current: 0.5A, 1.0A, 0.5A
 Load: Resistive load

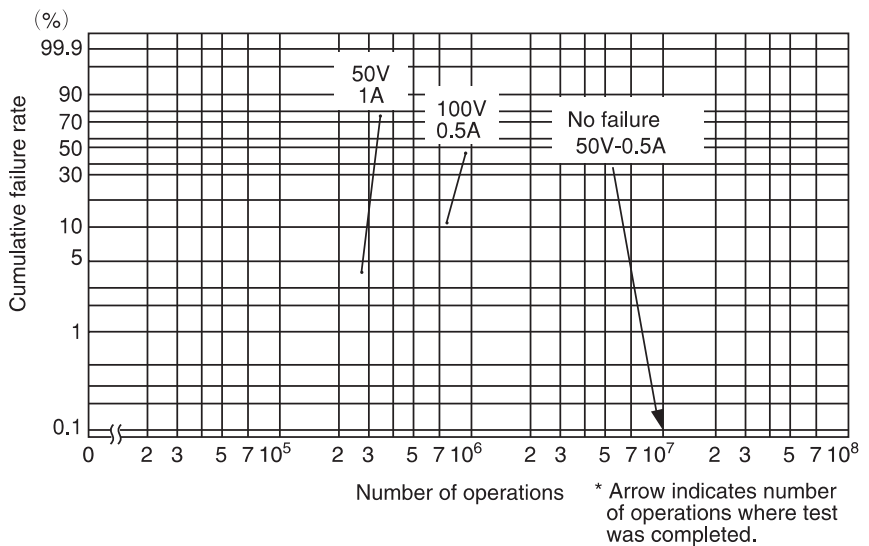

3